

# TECHNICAL DATASHEET



## EF REDUCED TEE 90°

04 Update - 03/2023

### TECHNICAL DATA

Article No	001 117 2042 0066
d1 (mm)	63
d2 (mm)	32
D (mm)	80
Z (mm)	164
L (mm)	92
le1 (mm)	49
le2 (mm)	46
m (mm)	23,8
Weight (Kg)	0,324
Box Quantity (pcs)	30
Box Dimension (cm)	55x30x42

### INJECTION MOULDED

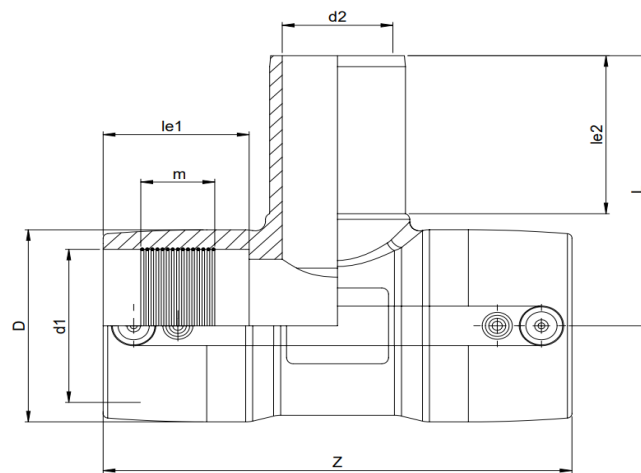

### IDENTIFICATION OF PRODUCT

D(mm)	63-32
SDR	11
RAW MATERIAL	PE 100
PRESSURE CLASS	16 Bar Water 10 Bar Gas
TRADEMARK	NTG
EXECUTION	Injection Moulded
STANDARD	EN 12201-3 EN 1555-3 AS / NZS 4129
SPECIFICATION	Suitable for SDR9...11 pipe 4 mm pin connectors

### EF SPECIFICATION

WELDING VOLTAGE	40V
RESISTANCE	3,40 Ω
WELDING TIME	80 Sec.
COOLING TIME	10 Min.
WINDING TYPE	Monofilar
WELDING BARCODE	



971420310633403406080112

Tolerance on diameters and thickness according to the standards. The other dimensions are specialized. Tolerance  $\pm 5\%$ . NTG PLASTIK reserves all the right to change any information without giving prior notice. The production, distribution and utilization of this document without explicit authorization is prohibited.